

A TPC for Low Background  $^{220}\text{Rn}$  Measurement

I. Blevis C. Hargrove D. Sinclair

Center for Research in Particle Physics

**Abstract**

A TPC MWPC with low backgrounds has been built to measure low levels of  $^{220}\text{Rn}$  emanated from samples of trapped  $^{224}\text{Ra}$ . The signal is carried into the TPC by the chamber gas recirculation system. The Rn  $\alpha$  decay in the chamber is uniquely identified by the  $\alpha$  energy and range and the energy, range, position and timing of the daughter  $^{216}\text{Po}$   $T_{1/2} = .15\text{ s}$   $\alpha$  decay. A sensitivity of .03 pCi was measured, but the potential of the technique is 10 to 50 times lower.

**1. Introduction**

In some applications the  $^{232}\text{Th}$  chain activity of a sample is desired. A high sensitivity assay is being sought for example in the effort to build ultra low background water Cherenkov detectors such as the Sudbury Neutrino Observatory (SNO) [SNO 87]. There the problem is to assay in particular the  $^{208}\text{Pb}^*$  activity at the bottom of the chain because of the subsequent 2.6 MeV  $\gamma$  which is a background to the neutrino signal. Since the chain may be significantly out of equilibrium at its last long lived isotope  $^{228}\text{Th}$ ,  $T_{1/2} = 1.9\text{ yr}$ , it is preferable to assay below this point in the chain. As well, since the next daughter  $^{224}\text{Ra}$  has a significantly different chemical mobility than the parent Th and a sufficiently long lifetime,  $T_{1/2} = 3.66\text{ days}$ , to be carried quite far from the parent, it is desirable to assay directly for Ra instead of Th. Following the Ra decay the chain decays quickly to the stable species  $^{208}\text{Pb}$ , so intermediate species are difficult to assay. Pb assay is a possibility [Shatkay 92], but Ra assay can be extended to use as Ra cleanup as well.

In natural water samples sensitivities of Rn detection of  $\sim 7000\text{ cpd}$  ( $\sim 2\text{ pCi}$ ) have been achieved using  $\text{MnO}_2$  to concentrate and extract Ra from the water, and a gas stream to collect and transport the emanated Rn to a  $\text{ZnS}(\text{Ag})$  scintillation counter [Rama 87]. Most of the background ( $\sim 90\%$ ) was attributed to emanation from materials of the Rn transport system, as well there was a loss in efficiency in the transport ( $\sim 80\%$ ) attributed to the lack of geometrical optimization. The  $\text{ZnS}(\text{Ag})$  cell itself was supposed to contribute as little as 150 to 15 cpd which would represent then the sensitivity of a cleanly built, optimized system. A remaining difficulty of this system for an ultra-low level application is the build up of the intermediate species  $^{212}\text{Pb}$  ( $T_{1/2} = 11\text{ hours}$ ) signal due to measurement of past samples. Another difficulty is the confinement to small sample size. The efficiency of the Ra extraction step can be essentially 100% [Moore 75], and samples of the  $\text{MnO}_2$  material have been found to give backgrounds at or below the sensitivity of these counting devices [Moore 85].

It would be possible then to improve the sensitivity of the assay by 3 modifications: 1 to increase the water sample size and the amount of  $\text{MnO}_2$  used, 2 to build the apparatus

from specially selected and cleaned materials (cleaned of Th), and 3 to positively identify the  $\alpha$  decay in the counter. These criteria are the motivations for the design of the Time Projection Chamber (TPC) detector.

As an intermediate step a 10 liter single wire proportional chamber (PC) was built [Ferraris 87].  $\alpha$  decay tracks ( $\sim 5$  cm) were small with respect to its volume and so the  $^{220}\text{Rn}$  was brought in with the chamber gas at 1.5 l/min. Using the  $^{220}\text{Rn} - ^{216}\text{Po}$  timing coincidence and the energies of the  $\alpha$ 's to identify the signal, a sensitivity of 2 cpd for the detector alone was measured. The next step was the 74 liter multiwire PC operating as a TPC. The residence times of 5-10 minutes and the gas flow rates of 10's of liters per minute would permit the increased size of the  $\text{MnO}_2$  cartridge, and the position measurement in the detector would help reduce the background due to the detector walls.

## 2. Description of TPC

The TPC, figure 1, is primarily a drift volume of about 74 liters. It is 46cm x 50cm x 32cm (x,y,z), the volume being divided into 2 halves vertically by a horizontal central cathode foil. It is constructed 'log cabin' style of alternate layers of teflon bars and square copper electrodes included to adjust the edge E-field configuration.

The endcaps on the top and bottom are each constructed of a cathode plane and an anode plane. The cathode plane consists of 32 copper strips 1cm wide glued to a lexan backboard. The anode plane consists of 32 anode wires (200  $\mu\text{m}$  diameter) located in a plane 1 cm closer to the center than the cathode plane and at  $90^\circ$  to the strips. Gain control cathode wires were located between the anode wires. The potentials on the electrodes were chosen to achieve a drift potential of 250 V/cm. At the operating pressure of 720 Torr in P10 gas, the reduced E-field was .30 V/cm/torr and the electron mobility was a maximum [Sauli 77]. Because of the abundant primary ionization available from  $\alpha$  particles, the gain was lowered to 100 by the choice of the anode voltage and wire diameter.

The central foil is 3  $\mu\text{m}$  thick Mylar, coated on both sides with 15 nm Al. The mylar was masked with tapes during electron beam evaporative deposition of the Al coating, and then the tapes were removed to give two concentric regions: an inner field and trigger antenna region, and an outer field region. This reduced the capacitance on the input of the trigger amplifier to half of the value with the regions joined. This translates first into reduced trigger signal noise and thus into increased z resolution.

The chamber gas was a standard mixture of Argon (90%) and Methane (10%), (P10). The P10 gas bearing the Rn signal was bought in through holes on one wall of the TPC and exhausted from holes on the opposite wall. It was recirculated through a sampler board at 0-5 l/min and refreshed at a slower rate. A 'decay' tank in the circulation loop caused the gas to stand for about 10 minutes after contact with most of the gas handling system before being passed through a Ra bearing sample. Since the TPC construction was not gas tight it was housed in a large stainless steel low pressure vessel to allow control of the gas environment. The vessel also served as a electronic pickup shield. In the construction of the gas system particular attention was made to the choice of

radioactively clean materials. Ultrapure Copper tubing and stainless steel fittings have been used, as well as a teflon coated diaphragm circulation pump.

The DAQ trigger, figure 2, was provided by a sensitive current amplifier connected to the central plane. To yield good measurement of drift times and thus the z coordinate of particle trajectories, the trigger incorporated a low threshold trigger as well as a high threshold trigger set for  $\alpha$  particles avalanches. The first threshold was intended to fire on the signal from the drifting primary ionization of the  $\alpha$ . This signal was embedded in the amplifier noise so the threshold was set to give 1-4 KHz trigger rate to limit the dead time. The maximum drift time was  $2 \mu$  s. If an avalanche signal (equivalent to 200 KeV) was not received within  $8 \mu$  s, a fast-clear was issued. This resulted in a 1-3% dead-time, and a z resolution of 3 cm FWHM. The full trigger also provided an ADC gate for measurement of the ionization collected on the anodes and cathodes, and a CAMAC LAM.

The signal readout is also shown in figure 2. The 132 signal electrodes are read-out through integrating pre-amplifiers located outside the stainless steel box. The shaping time was set at  $20 \mu$  s. They drive twisted pairs to charge sensitive ADCs (Lecroy 1822) and to differentiator-discriminators (CRPP); In the differentiator-discriminators the signal is differentiated and mixed with a 10% negative admixture of the input integrated signal to sharply define the pulse trailing edge. The leading and trailing edges are registered on TDCs (Lecroy 1879). The ADCs and TDCs are readout by a Dr B Struck FASTBUS System 102 to a PC486DX computer in an interrupt driven fashion upon receipt of the LAM at the computer.

### Signal Signature

$^{220}\text{Rn}$  brought in on the counting gas  $\alpha$  decays in the volume of the TPC. The daughter  $^{216}\text{Po}$  maintains the same x,y coordinates in the z oriented E-field, no matter what the charge state of its production, and then decays as well with  $T_{1/2} = .145$  sec. As a first level data analysis the time correlated decays serves to count Rn-Po pairs. To reduce the background of chance coincidence of singles, the correlation of positions in x and y is used. To eliminate the real  $^{220}\text{Rn}$  background given off from detector materials, a fiducial cut on the Rn and Po position in x,y, and z is made.

## 3. Experimental Performance

### Efficiency and Background

The signal losses of the TPC setup are the following. At 2 lpm the Radon transport from sample to detector takes  $\sim 4$  seconds during which time some of the  $^{220}\text{Rn}$  will have decayed resulting in a  $6 \pm 1\%$  loss. At this flow rate the loss of Rn out the TPC chamber due to the recirculation was minimal. During the time taken to readout the electronics to the computer the system may miss decays of  $^{216}\text{Po}$  ( $T_{1/2} = .145$  sec) which occur shortly after the  $^{220}\text{Rn}$  decays. The readout deadtime is 10 ms which results in a loss of Rn-Po pairs of  $5 \pm 1\%$ . The loss due to the 1st level trigger dead time is  $3 \pm 1\%$ . Thus the combined efficiency of the detector, the trigger, and the DAQ was  $88 \pm 2\%$ .

Offline, the data was examined to further identify Rn-Po  $\alpha$  pairs. The space correlation

cut shown in figure 3 caused a loss of 14%. The figure shows the distribution of x and y coordinate differences between the first and second  $\alpha$ 's of a time correlated pair. Real Rn-Po pairs peak at 0 and a background due to singles extends to large values. The figure also shows the slightly worse resolution in y due to the induced cathode signal. The time correlation cut of  $3(T_{1/2}^{216}\text{Po})$  caused a partially correlated loss of 12%. The combined efficiency of the detector, the trigger, the DAQ, and the Rn-Po identification was 70% .

With this 70% efficiency the background in the detector was 40  $^{220}\text{Rn}$  decays per day. The  $\Delta t$  distributions for the recorded  $\alpha$ 's in a background run, before and after the spatial cut, are shown in figure 4. A fiducial volume cut on signals on the outside anodes and cathodes gave a further reduction of background to 20 dpd. The attendant signal loss was 30%, for an overall efficiency of 50%. Figure 5 shows the hit wire distributions in the x and y directions (across the anodes and the cathodes) for real signals with the fiducial cut.

The overall efficiency was verified using a 2 cc, .1 Bq  $^{228}\text{Th}$  source prepared by the method documented in [Ferraris 87]. The Rn emanation efficiency at 1000 bed volumes per minute was expected and measured to be  $\sim 90\%$ . (also determined from  $\gamma$  counting studies [Laberge 93]). Since this measured emanation efficiency measured was high, unknown causes of losses are limited.

After extensive handling and only partial cleaning of the TPC using simply a Methanol wipe, the background was measured for 10 days (8 runs of 1-2 days) and analysed as described above. The count rate was  $21 \pm 6$  (systematic error) dpd. This background was associated with the surfaces of the TPC, which suggests that it might be reduced by further cleaning.

In the SNO water monitoring scheme, the Ra from 300 tonnes of detector water could be filtered (extracted) with nearly 100% efficiency. The emanated radon (about 70%) could be measured then in the TPC. The above efficiency and background implies that a level of  $3 \times 10^{-15}$  gm Th / gm water could be determined with 11% accuracy in a one day measurement on the TPC.

Futher reductions in the background of the TPC would result in smaller required water sample size, shorter counting times, or smaller error bounds in the Ra assay.

### Energy Resolution

The Energy resolution of the TPC is 3% FWHM for an 5.5 MeV  $^{241}\text{Am}$   $\alpha$  source that was inserted on a rotating metal isopotential rod into the TPC. 2% can be attributed to electronic noise indicating a combined chamber and source resolution of 2% FWHM. Preamplifier gain variations were callibrated away using a pulser circuit. Chamber effects such as recombination of the primary ionization in different source orientations or cross-talk due to high gain have been reduced by enlargement of the usual PC anode wire diameter to 200  $\mu\text{m}$  and by reduced anode potentials. Gain variations in the chamber due to loose mechanical assembly, edge field inhomogeneities, and pressure fluctuations have been seen but not corrected for. In a final configuration these effects could be callibrated away to yield the 3% resolution for a distributed test source. Presently the energy resolution for Rn brought in on the gas line is 7% FWHM. Figure 6 show the  $\alpha$  spectra from Rn source data. In figure 6a, an uncut spectrum shows the Rn peak just

separated from the closeby Po peak, which is skewed to lower energy by E loss in the central cathode material near which most of the Po decays occur. Figure 6b show data with a time correlation cut to select the Rn peak shown. This resolution is good enough for the purposes of the TPC since the time and space cuts already characterize the signal well.

#### 4. Conclusions

We have developed a low background, high efficiency TPC for  $^{220}\text{Rn}$  monitoring. It has served to study radiopurity in the SNO neutrino detector research and development program. With computer aided data analysis it is capable of measuring the position, orientation, time, energy, energy loss distribution (along the path), and range of  $\alpha$  decays anywhere in its volume. The two  $\alpha$  correlations enable it to measure the signal due to  $^{220}\text{Rn}$  in a background reduced way. A fiducial cut eliminates signals due to the low natural levels of Rn in the selected construction materials. The redundancy in its measurement capability allows it to operate in fluctuating and unusual conditions.

#### 5. References

- SNO 87 Sudbury Neutrino Observatory Proposal, SNO-87-12  
Shatkay 92 M. Shatkay et al, General concepts for monitoring  $^{212}\text{Pb}$  in the SNO experiment, SNO-STR-92-092  
Rama 87 A New Method for the Rapid Measurement of  $^{224}\text{Ra}$  In Natural Waters, Rama et al, Marine Chemistry, 1987  
Moore 75 W. S. Moore, L. M. Cooke, Radium Removal from Drinking Water, Nature, 253 262, 1975  
Moore 85 W. S. Moore, R. M. Key, J. L. Sarmiento, Techniques for the precise Mapping of  $^{226}\text{Ra}$  and  $^{228}\text{Ra}$  in the Ocean. Journal of Geophysical Research, 90, C4 9683, 1985  
Ferraris 87 A. P. Ferraris, D. Sinclair, N. W. Tanner, Radium and Thorium in Water, SNO-87-12  
Sauli 77 F. Sauli, Principles and Operation of Multiwire Proportional and Drift Chambers, CERN-77-09  
Laberge 93 G. Laberge and C. Hargrove, The measurement of  $^{220}\text{Rn}$  extraction efficiency for various pressures, flow rates and  $\text{MnO}_2$  Depths, SNO-STR-93-063

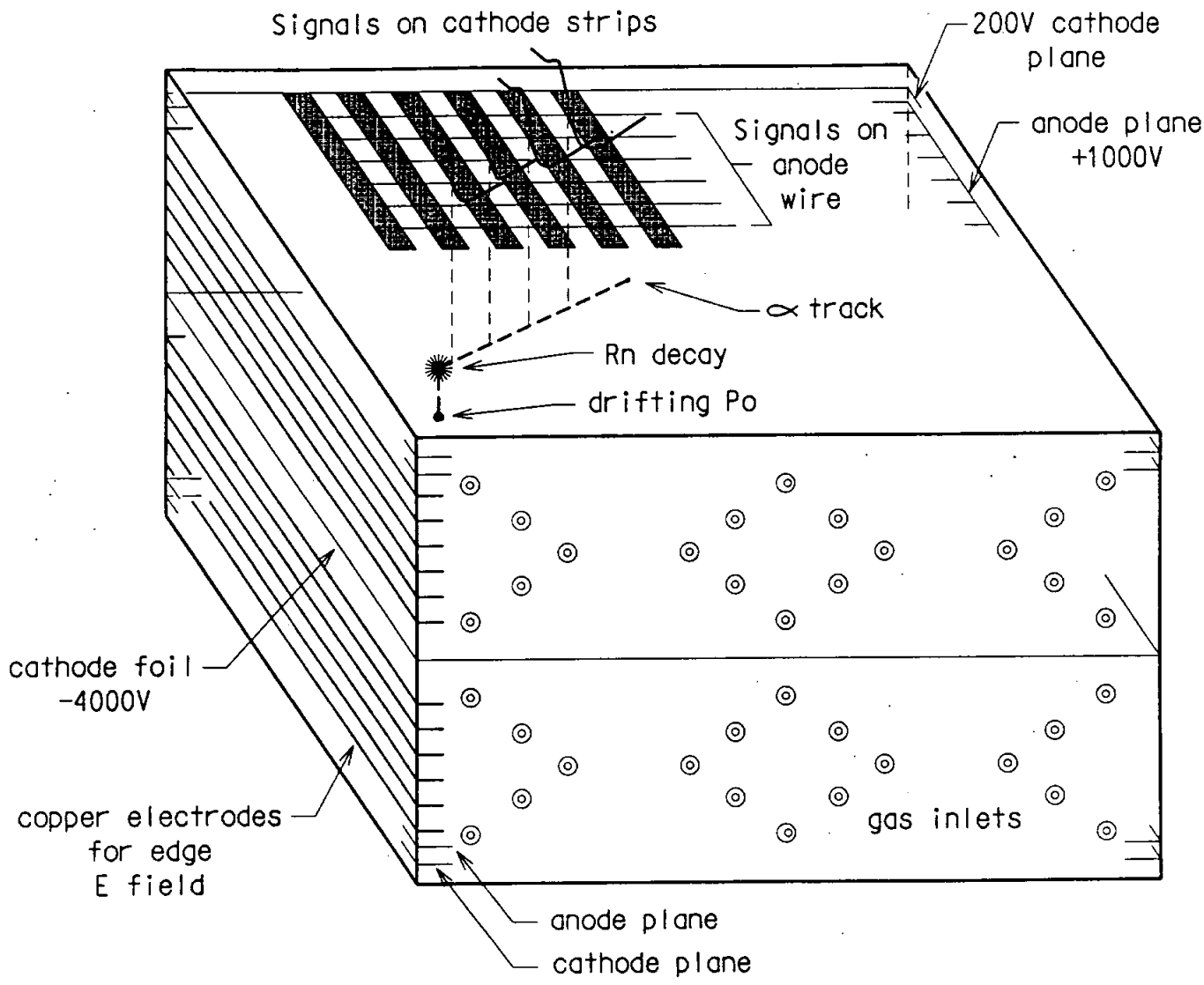

Figure 1. Schematic of TPC

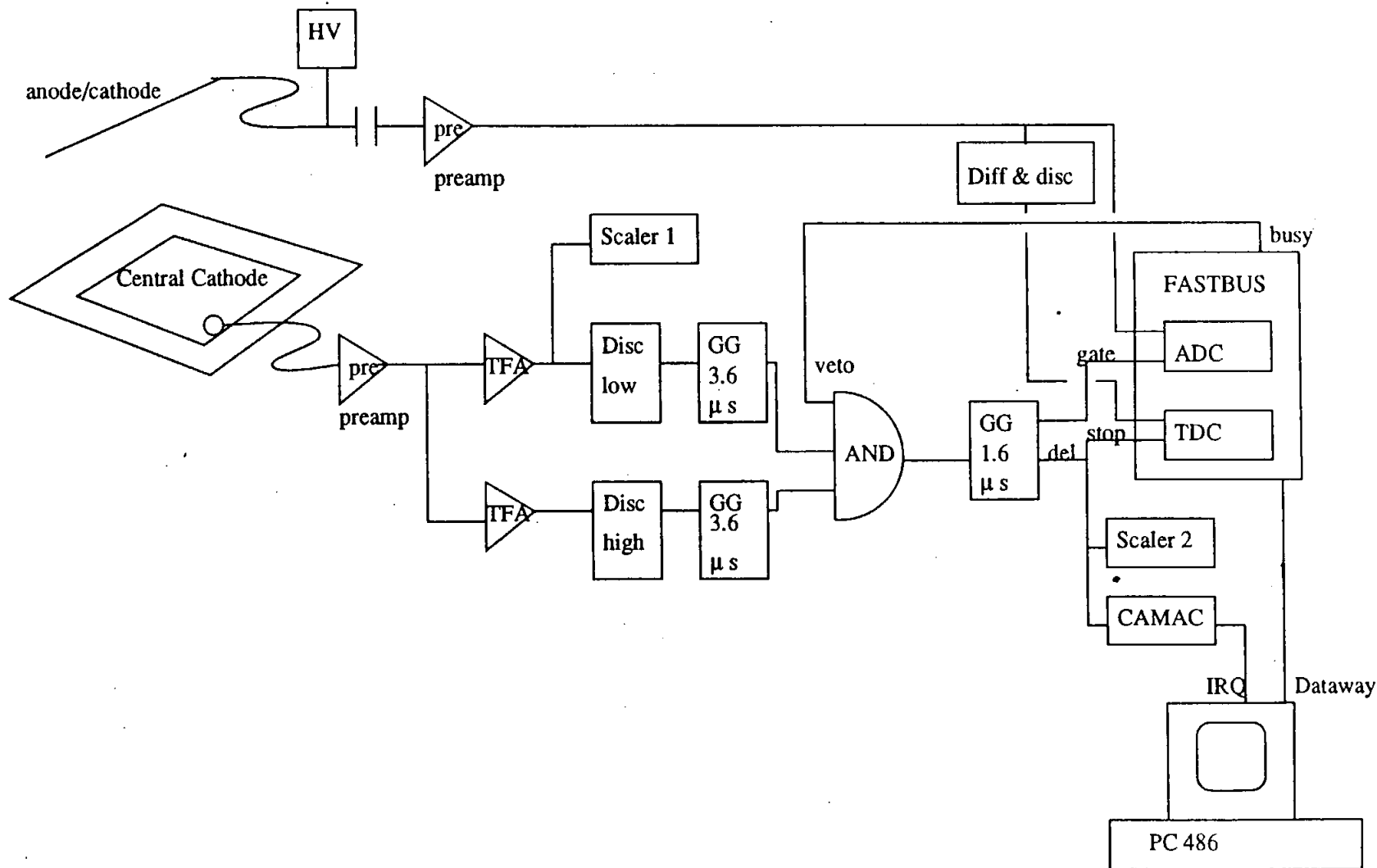

Figure 2. Readout and Trigger

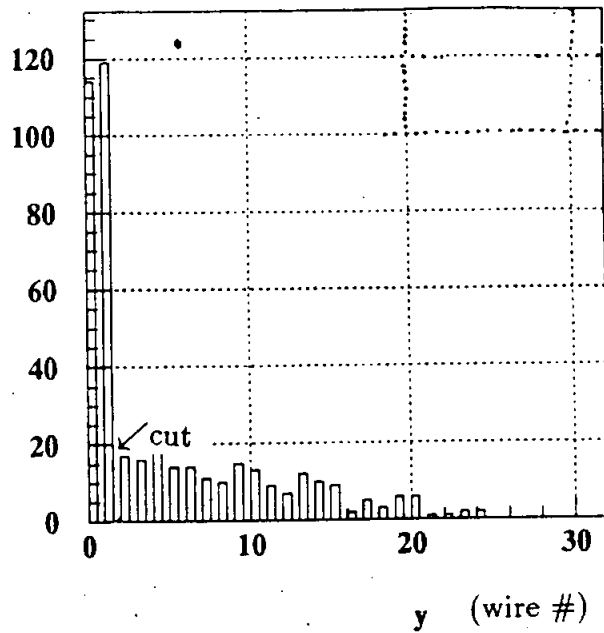
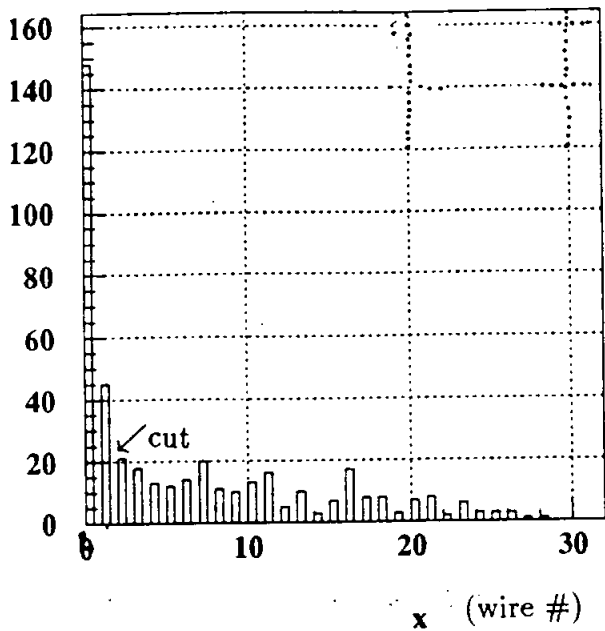
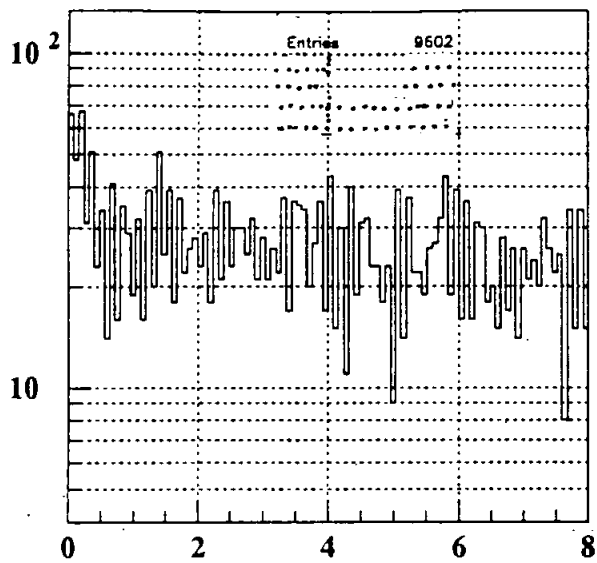
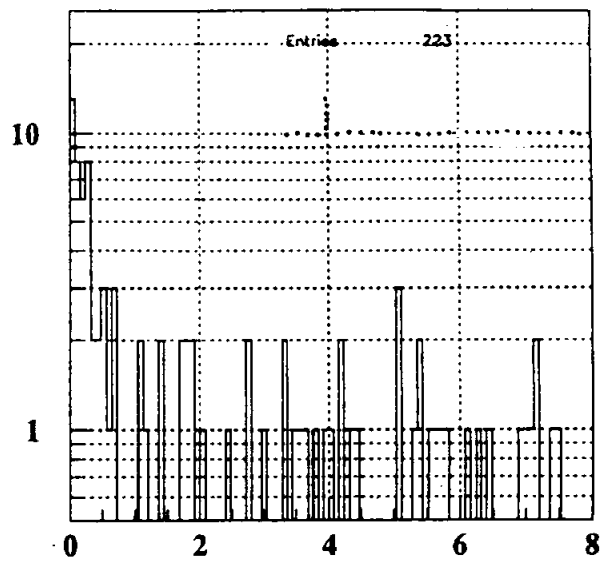

Figure 3. Correlation of Rn-Po in x and y Position





$\Delta t$  (sec)



$\Delta t$ , Rn-Po position cut. (sec)

Figure 4. Time Interval Distribution; Background data.

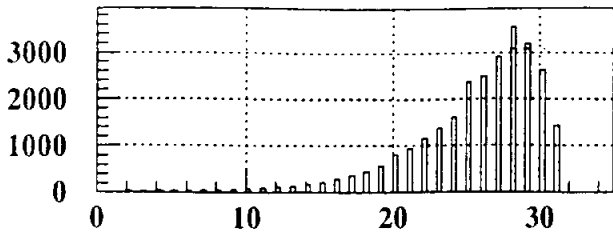

bot x

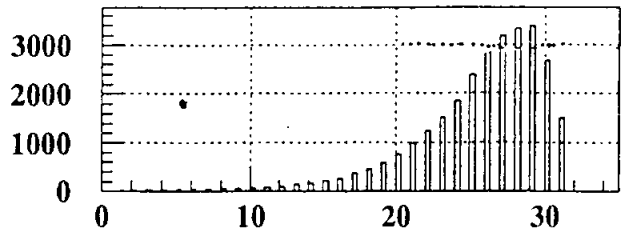

top x

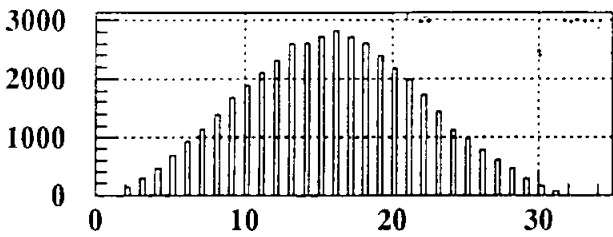

bot y (wire #)

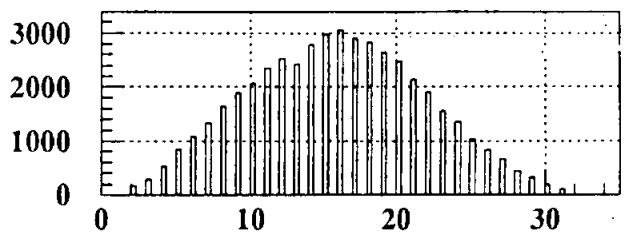

top y (wire #)

Figure 5. Hit Distributions, top and bottom , x and y; Fiducial cuts.

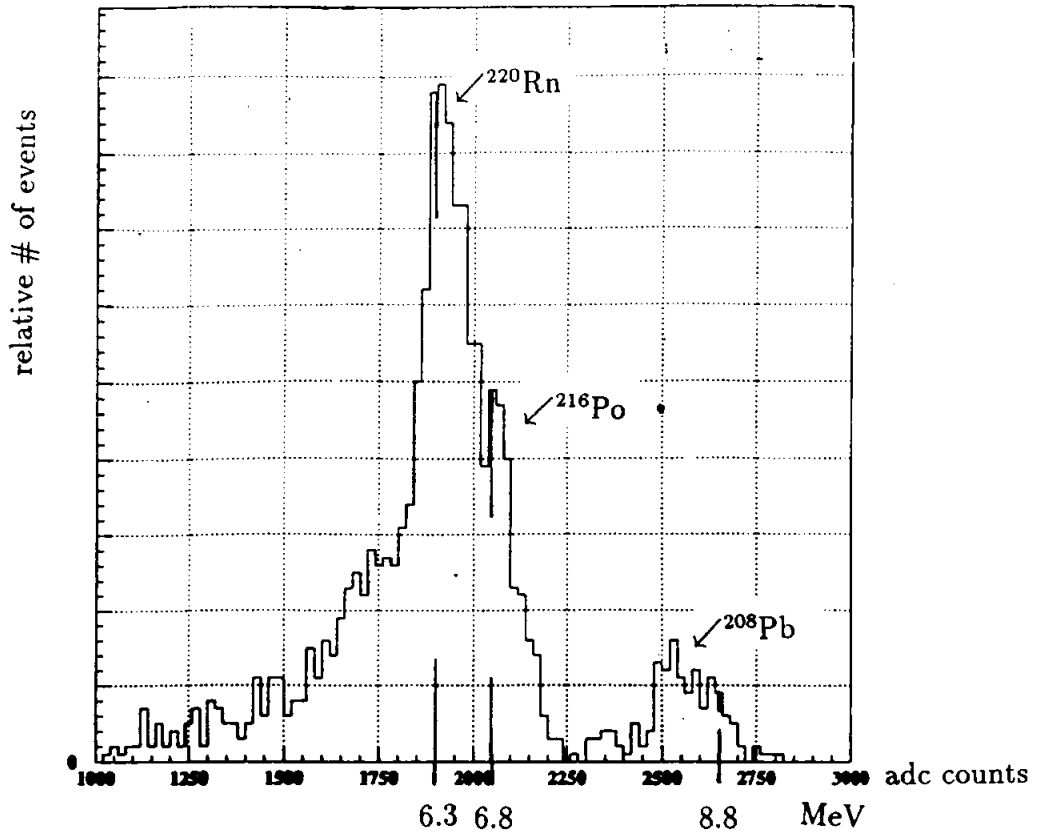

a

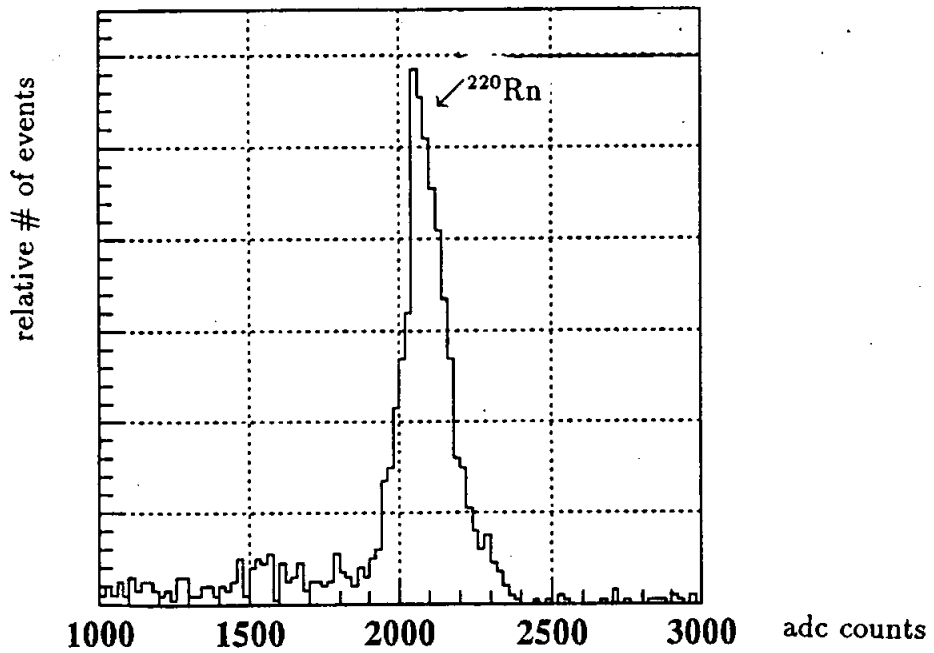

b

Figure 6. Energy Distribution  $^{224}\text{Ra}$  Source a, with  $\Delta t$  cut b.